

Conference Matrix

Friday, September 29, 2017

Room #	Session 1 9:10-10:00	Session 2 10:10-11:00		Session 3 11:40-12:30		Session 4 1:55-2:45	Session 5 2:55-3:45	Session 6 3:55-4:45
Floor 3 Springs A	Hands-On/Minds-On Social Studies	Collecting Oral History	Vendor Breakout – 11:00-11:30	Take A Walk with Me through History!!!	Lunch - 12:45-1:45	ESOL - Who, What, Where, When & HOW?	Active Seating in the Social Studies Classroom	Making It Relevant: Teaching Social Studies Through Simulations
Floor 3 Springs B	EVERFI- Leveraging Free Web-Based Technology to Teach Critical Life Skills in the Social Studies Classroom	Hang Ten! Surfing Discus to Teach Middle & High School Standards		Give Me 5! K-5 Resources Tied to the Standards		Authentic & Engaging Social Studies in the Elementary Grades	Writing Journey for a Personal, Different Perspective on Hiroshima	Bringing WWII Hiroshima & Historical Fiction to the Modern Classroom
Floor 3 Springs C	Integration African American History in Curriculum of Grades K-12	HC PEG - How to Embed Themes of Social Studies into Every Lesson		Civil Rights: In their Own Words		Engaging Review Strategies	Developing Compelling Questions	Using DBQs
Floor 3 Springs D	Stop, Collaborate, & Literacy	EDpuzzle: Connecting the Pieces		Speak Up: Library of Congress Teaching with Primary Sources		Reading Like Historians: Experience a Two-Day Inquiry Using Three Primary Documents	Beyond February: Resources for Seamlessly Integrating African American History Content	Bringing PBL's to Your Social Studies Classroom
Floor 3 Springs E	Modern History of Judaism in Europe	Teaching Globalization with "Cotton Road"		Making Middle School Social Studies "Stick": Practices to Increase Student Engagement		Days of Future Past: The Social Studies Classroom in the 21 st Century	What! Social Studies Can Support ELA with the TDA Process?	Reaching ELLs - Building Context, Confidence, & Vocabulary in World History
Floor 3 Springs F	Using History Clips to Promote Historical Thinking & Understanding	The Civil War, South Carolina, & African American Agency		The Annual Social Studies Assessment Update from the South Carolina Department of Education		Exploring the LOC Primary Sources	But There's Gotta Be Power-Ups! Game Design in the Classroom	Engagement through Collaboration: Planning for Success with Verso App
Floor 3 Springs G	Text Dependent Analysis Questions-Close Reading in the Social Studies Classroom	Blended Learning in Social Studies		Visual Literacy in an Inquiry Based Learning Classroom		Using Historical Fiction to Teach about the Holocaust & Genocide	Soundtracks: Songs that Defined History	Ken Burns' Vietnam: Examining the Education Aspects
Floor 3 Springs H	Ready-made Geography: Inquiry Modules for High School Geography	Primary Sources in Geography: An Example from 1850s South Carolina		South Carolina: Explore by Atlas, Poster, & Giant Map!		Mystery Skype – Learning without Borders	3-D Mapping to Develop Geographic Understanding with Students with I/DD	SC Social Studies Professors Meeting

Room #	Session 1 9:10-10:00	Session 2 10:10-11:00		Session 3 11:40-12:30		Session 4 1:55-2:45	Session 5 2:55-3:45	Session 6 3:55-4:45
Floor 3 Springs J	Avoiding the Second Semester Slump: Engaging the AP History Student	The Supreme Court, Its Decisions, & Your Students		AP US History: A Reader's Perspective		Explaining the New AP History Writing Rubrics	Incorporating RTI in the HS Social Studies Classroom	US History & English III Reading & Writing Collaboration
Exhibition Hall Poster Sessions, Carolina E, & the Exhibition Hall are located on the Second Floor.								
Room #	Session 1 9:10-10:00	Session 2 10:10-11:00	Vendor Breakout – 11:00-11:30	Session 3 11:40-12:30	Lunch - 12:45-1:45	Session 4 1:55-2:45	Session 5 2:55-3:45	Session 6 3:55-4:45
Floor 2 Carolina E	ETV's Learning Why Lessons for Social Studies Teachers	Great History Instruction Includes Historical Figures from Statehood to Today		ETV Does That?		Webtools for Teachers	McGraw-Hill Networks Online Platform with LearnSmart	Active Learning in the World History Classroom
Floor 2 Poster Table 1	South Carolina History Day, Coastal Carolina University	Rivers, Reefs, & Pipelines: Environmental Challenges in the Middle East		Case Studies in the Social Studies Classroom		Online vs. Face-to-Face Discussions	Singing Your Way Through American History	Inquiry Based Introductions to Geographic Thinking
Floor 2 Poster Table 2	Kickin' Djibouti: Fantasy Geopolitics in World Geography	Cross-Curricular & Vertical Planning for Social Studies		History Underground: Breaking Down SC USHC Standards		What's YOUR Story?	What's YOUR Story?	Gallery Walk: The Most Versatile Lesson Plan Out There!
Floor 2 Poster Table 3	Bringing China into Economics Classes	Google for Social Studies: More Than Just Searching		Teaching the Arab-Israeli Conflict & Peace Process		I Found It! Using Scavenger Hunts to Explore Local History		
Floor 2 Poster Table 4	Children from South Carolina's Past Tell Their Stories	Sharing is Caring in Middle School		Native American Written Records		2018 Summer Institute for School Teachers: America's Reconstruction - The Untold Story		

**Saturday
September 30, 2017**

General Session Continental Breakfast			
Room #	General Session 9:00 – 10:00	Saturday Session 1 10:00 – 10:50	Saturday Session 1 11:00 - 11:50
Springs A, B, C	Everybody Gets an F Jed Dearybury		
Springs F		Empowering Society's Marginalized Groups: The Economics of Inclusion	The Economic Impact of Disasters
Spring G		The Press Vs the Presidency: A Media Literacy Lesson	Continuity & Changes – 2020 Social Studies Elementary Standards – Middle Level
Springs H		Continuity & Changes – 2020 Social Studies Elementary Standards – Elementary	Continuity & Changes – 2020 Social Studies Elementary Standards – High School

Map of DoubleTree by Hilton Myrtle Beach, SC

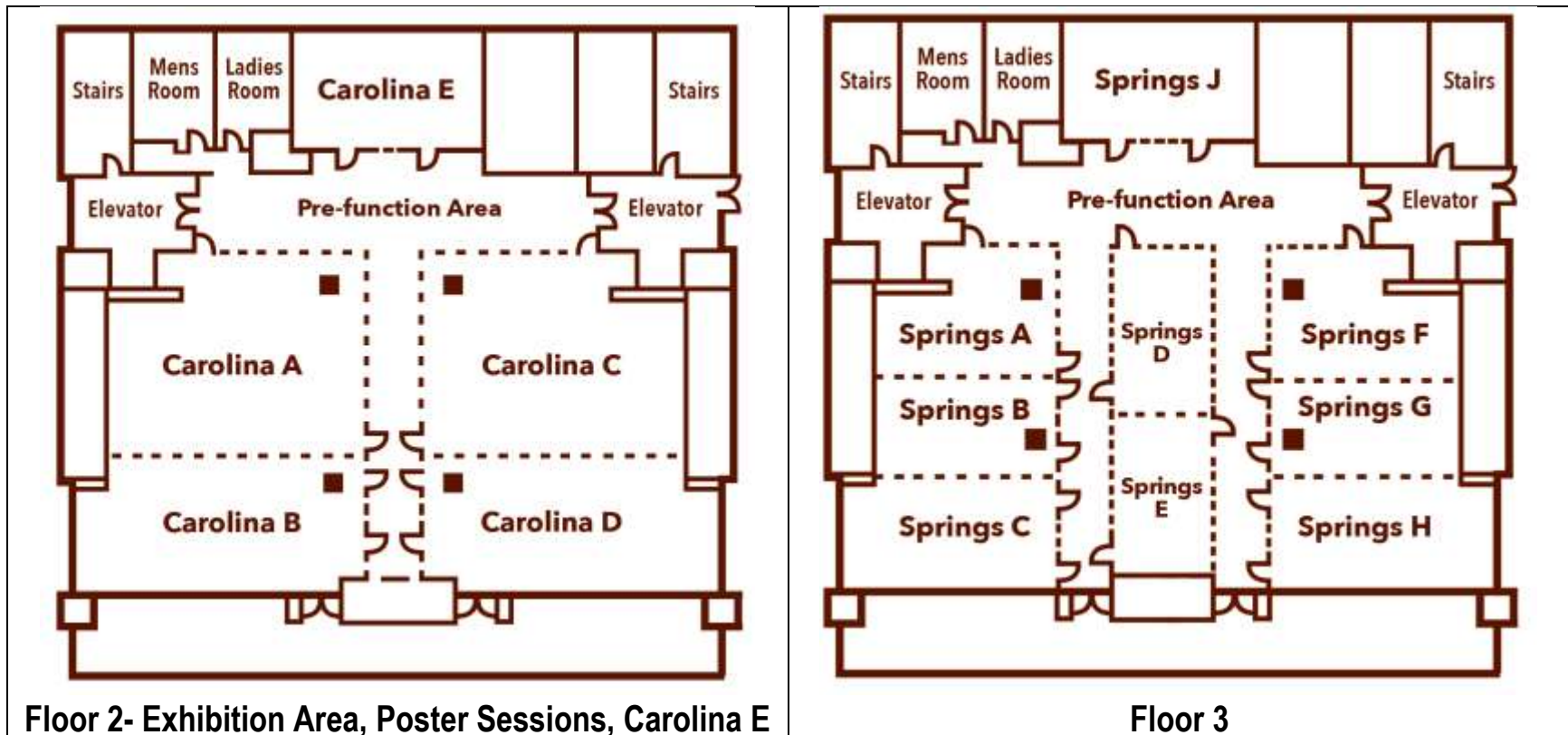

Concurrent Sessions

Friday, September 29

Session 1

9:10 - 10:00

Floor 3 Springs A

Hands-On/Minds-On Social Studies

Participate in a model of building engaging, active lessons through "bump games" and using hands-on resources to build background knowledge to improve literacy and reading in a content area.

Presenter: Christina Carroll, Social Studies School Service/Nystrom Education

Focus: Administration, Content, Instruction/Elementary

Floor 3 Springs B

EVERFI- Leveraging Free Web-Based Technology to Teach Critical Life Skills in the Social Studies Classroom

EVERFI partners with forward thinking organizations to provide web-based standards aligned, resources to schools at NO COST. Each resource focuses on addressing critical life skills in topics such as Financial Literacy, Civic Engagement, Diversity and Inclusion and more. In this session you will preview the programs, learn implementation strategies and create a plan to use them with your students. You will walk away with everything you need to get started right away! Please bring a laptop or table to this session.

Presenter: Belle Stoker, EVERFI

Focus: Content, Instruction/Elementary, Instruction/Middle School, Instruction/Secondary School

Floor 3 Springs C

Integration African American History in Curriculum of Grades K-12

Using A Teacher's Guide to African American Historic Places in South Carolina and Integrating Art into Classroom Instruction presenters will discuss strategies for integration African American historic and culture throughout K-12 curriculum.

Presenter: Jannie Harriot, SC African American Heritage Foundation

Chanda Robinson, Richland District One

Focus: Administration, Assessment/Evaluation, Content, Instruction/Elementary, Instruction/Middle School, Instruction/Secondary School, Research

Floor 3 Springs D

Stop, Collaborate, and Literacy

Come and see how to collaborate with non-Social Studies teachers can benefit not only your students but you as well. Best practices and literacy skills will be shared.

Presenter: Jill Knight, Darlington County School District/Mayo High School for MST

Focus: Content, Multipurpose/General

Floor 3 Springs E

Modern History of Judaism in Europe

Rikki Davenport and Rose Marie Craft, 8th grade South Carolina history teachers and Centropa fellows, will present teaching resources and professional development/ travel opportunities for teachers made available through Centropa. Centropa is a non-profit, Jewish historical institute dedicated to preserving 20th century Jewish families stories and photos from Central and Eastern Europe and the Balkans, and disseminating these stories and photos through films, books and exhibitions.

Presenter: Rikki Davenport, Moultrie Middle School

Rose Marie Craft, Bamberg-Ehrhardt Middle School

Focus: Content, Multipurpose/General

Floor 3 Springs F

Using History Clips to Promote Historical Thinking and Understanding

At the middle school level, producing history clips deepens students' overall historical understanding and is both engaging and student centered. This presentation will focus on using multiple sources to build a position statement, analyzing primary and secondary sources, and developing inquiry skills through the use of technology.

Presenter: Nora McMillan, Northwest Middle School

Bea Bailey, Clemson University

Focus: Instruction/Middle School

Floor 3 Springs G

Text Dependent Analysis Questions-Close Reading in the Social Studies Classroom

Text Dependent Questions-Close Reading in the Secondary Social Studies Classroom. . .How does one begin to devise and deploy "quality questions with highly intentional purposes" that engage students in rigorous social studies standards? Based on Fisher & Frey Text-Dependent Questions 2015.

Presenter: Rosaline Jordan, Lakeview Middle School

Focus: Assessment/Evaluation, Content, Instruction/Middle School, Instruction/Secondary School

Floor 3 Springs H

Ready-made Geography: Inquiry Modules for High School Geography

Explore a suite of geography modules on National Identity, Population and Natural Resources, Migration, Global Climate Change, Water Resources, and Global Economy. The modules offer regional case studies useful for high school World Geography or AP Human Geography.

Presenter: Jerry Mitchell, South Carolina Geographic Alliance

Focus: Instruction/Secondary School

Floor 3 Springs J

Avoiding the Second Semester Slump: Engaging the AP History Student

Presenters will share student-centered activities to increase engagement and break up the monotony of notes, graphic organizers, and textbook readings. Strategies are applicable to AP World, US, and European History.

Presenter: John Codega, AC Flora High School

Bailey Melvin, AC Flora High School

Focus: Content, Instruction/Higher Education

Floor 2 Carolina E

ETV's LearningWhy Lessons for Social Studies Teachers

Learn how to access and use project-based, 1:1, and traditional lessons that include essential questions, lesson progressions, links to resources, and assessments in your classroom.

Presenter: Lewis Huffman, SC ETV

Focus: Content, Instruction: Elementary, Instruction/ Middle School, Instruction/Secondary School

Floor 2 Poster Table 1

South Carolina History Day

This session will provide an introduction to the History Day program, its benefits to students and teachers, and ways to get involved. This will be a great way to introduce yourself to this great program that will benefit your students and your school.

Presenters: Angela Dembiczak, South Carolina History Day, Coastal Carolina University

Adam Powley, HCS Early College High School

Focus: Content, Instruction/Elementary, Instruction/Middle School, Instruction/Secondary School, Multipurpose/General, Research

Floor 2 Poster Table 2

Kickin' Djibouti: Fantasy Geopolitics in World Geography

This session goes over the use of www.FanSchool.org and the Fantasy-Sports type of games they have to get students to actively engage with the world around them. Come join us and draft the countries that will get you the most points!

Presenter: Wynne Boliek, Southside High School

Focus: Content, Instruction: Middle School, Instruction/Secondary School, Multipurpose/General

Floor 2 Poster Table 3

Bringing China into Economics Classes

China is one of our most important trading partners. This session provides practical ways to incorporate a teacher's experience in China into economics classes.

Presenters: Taylor Stephenson, South Pointe High School, Rock Hill Schools

Margaret Gillikin, Winthrop University

Focus: Content, Instruction/Secondary School

Floor 2 Poster Table 4

Children from South Carolina's Past Tell Their Stories

This session will provide strategies for elementary teachers hoping to utilize historical photographs of children in South Carolina for use in the social studies classroom.

Presenter: George Lipscomb, Furman University

Focus: Instruction/Elementary

Session 2

10:10-11:00

Floor 3 Springs A

Collecting Oral Histories

Collecting oral histories from Veterans, align to social studies standards, engaging students and collecting on an iPad filming with an iographer and then editing with IMOVIE. We will screen portions of our film: Oral Histories of SC Vietnam Veterans. Includes a presentation from the SC Military Museum, Director featuring SC Heroes, with stories to engage students.

Presenters: Linda Dennis, A Backpack Journalist
Stephan Jeffcoat, SC Military Museum

Focus: Assessment/Evaluation, Content, Instruction/Elementary, Instruction/Middle School, Instruction/Secondary School

Floor 3 Springs B

Hang Ten! Surfing Discus to Teach Middle & High School Standards

Come and learn keys to integrate online resource features into your standards-based lessons! For an interactive session, bring your mobile device. Features of Discus - South Carolina's Virtual Library will be highlighted.

Presenter: Linda Heimburger, South Carolina State Library

Focus: Instruction: Secondary School, Instruction: Higher Education

Floor 3 Springs C

HC PEG - How to Embed Themes of Social Studies into Every Lesson

This session will highlight an activity that exposes students to seeing social studies as a part of their daily life. The activity introduces HC PEG as a tool for application and analysis of course content while serving as a foundation for all social studies thinking skills.

Presenter: Stephen Corsini, SC Department of Education

Focus: Assessment/Evaluation, Content, Instruction/Elementary, Instruction/Middle School, Instruction/High School

Floor 3 Springs D

EDpuzzle: Connecting the Pieces

Want to have a blended/flipped classroom? Come check out how EDpuzzle can help with this transition of integrating technology and social studies.

Presenter: Jill Knight, Darlington County School District/Mayo High School for MST

Focus: Content, Instruction/Elementary, Instruction/Middle School, Instruction/Secondary School, Instruction/Higher Education, Multipurpose/General

Floor 3 Springs E

Teaching Globalization with "Cotton Road"

The documentary film "Cotton Road" can be used to teach concepts related to production, consumption and the global economy.

Presenter: Laura Kissel, University of South Carolina

Focus: Instruction/Secondary School

Floor 3 Springs F

The Civil War, South Carolina, and African American Agency

This session will use primary sources and methodologies to explore South Carolina's connection to Harriet Tubman, the 54th Massachusetts, Robert Smalls, and other African Americans in the Civil War.

Presenter: Timothy E. Hicks, The Learning Collaborative of Dent Middle School

Focus: Content, Instruction/Middle School, Instruction/Secondary School

Floor 3 Springs G

Blended Learning in Social Studies

The blended learning classroom utilizes technology to enhance the curriculum and encourage student communication, collaboration, critical thinking, and problem solving.

Presenter: Susan Turner, HB Rhame Elementary

Focus: Instruction/Elementary

Floor 3 Springs H

Primary Sources in Geography: An Example from 1850s South Carolina

This lesson uses primary sources to trace the journey of pineapples from the West Indies to Charleston. Students examine 19th century world trade (fruit farms, ocean voyages, enslavers, and the enslaved).

Presenter: Jerry Mitchell, South Carolina Geographic Alliance

Focus: Instruction/Middle School

Floor 3 Springs J

The Supreme Court, Its Decisions, and Your Students

The Supreme Court is one of the most important institutions in American government, yet can be very intimidating to teach. Come learn how to better breakdown Supreme Court cases for all levels of students and encourage discussion of Supreme Court decisions and Constitutional Law. Leave with resources, lesson plan ideas, and suggestions for how to better utilize guest speakers in your classroom. Join me in this session and learn how to bring the decisions of the Supreme Court to life in the classroom.

Presenter: Brea Amick, Spring Hill High School

Focus: Content, Instruction/Secondary School

Floor 2 Carolina E

Great History Instruction Includes Historical Figures from Statehood to Today

Let's explore historical figures from Active Classroom's thousands of inquiry-based modules that give teachers a variety of content and the power to differentiate for reading levels and learning styles.

Presenter: Christina Carroll, Social Studies School Service/Nystrom Education

Focus: Administration, Assessment/Evaluation, Content, Instruction/Middle School, Instruction/Secondary School

Floor 2 Poster Table 1

Rivers, Reefs, and Pipelines: Environmental Challenges in the Middle East

Experience and apply critical pedagogy around environmental crisis points in the Middle East that are being addressed through peaceful transboundary collaboration and the introduction of new technologies.

Presenter: Dori Gerber, Institute for Curriculum Services

Focus: Content, Instruction/Middle School, Instruction/Secondary School

Floor 2 Poster Table 2

Cross-Curricular & Vertical Planning for Social Studies

Social studies is the perfect discipline for combining reading comprehension, mathematics, physical and social sciences, arts, logic, and higher order thinking, benefiting every other aspect of school and life.

Presenter: Michelle E. C. Brown, Hillcrest High School, GCSD

Focus: Content, Instruction/Elementary, Instruction/Middle School, Instruction/Secondary School, Multipurpose/General

Floor 2 Poster Table 3

Google for Social Studies: More Than Just Searching

Google offers more than just a search box! Join me to learn how to use the Google Suite for Education to make your classroom more efficient, easily analyze student data, and keep students engaged.

Presenter: Samantha House, St. James Middle School/Horry County Schools

Focus: Administration, Assessment/Evaluation, Instruction/Middle School, Instruction/Secondary School, Multipurpose/General

Floor 2 Poster Table 4

Sharing is Caring in Middle School

No teacher should be an island - divide and conquer the standards and the work. Meet and share with other middle school teachers best practices and best lessons. We are all in this together, so let's work together! Bring your favorite lesson to share!

Presenters: Nancy Machamer, Palmetto Middle School

Zak Theus, Palmetto Middle School

Chris Garrison, Palmetto Middle School

Focus: Content, Instruction/Middle School

Session 3

11:40-12:30

Floor 3 Springs A

Take A Walk With Me Through History!!!

This workshop will add "zest" to your teaching as we walk through history and share some of the latest tools to educate and inspire!!! You won't be the same!

Presenter: Cindy Clark, Institute of History, Science and Technology

Focus: Instruction/Elementary, Instruction/Middle School, Instruction/Secondary School

Floor 3 Springs B

Give Me 5! K-5 Resources Tied to the Standards

Come learn 5+ ways to integrate online Discus resources into your standards-based lessons! For an interactive session, bring your mobile device. Features from Tumblebooks, BrainPop Jr., CultureGrams and more will be highlighted.

Presenter: Linda Heimbürger, South Carolina State Library

Focus: Instruction/Elementary

Floor 3 Springs C

Civil Rights: In their Own Words

Eight Civil Rights leaders explain their journeys compiled in digital oral histories. They are edited to short vignettes for instruction but the raw footage can be used by students to create documentaries on topics of interest.

Presenter: Elizabeth King, South Carolina Department of Education

Stephen Corsini, South Carolina Department of Education

Focus: Content, Instruction/Elementary, Instruction/Middle School, Instruction//Secondary School

Floor 3 Springs D

Speak Up: Library of Congress Teaching with Primary Sources

Speak Up: Using Primary Sources to Engage Students is a professional development workshop for teachers that is created and led by the South Carolina Historical Society with LOC funding. The goals of this workshop are to 1) increase educators' access to and use of primary sources available to them and 2) establish best practices and effective ways for teaching with primary sources.

Presenters: Bailey Knight, SC Historical Society

Focus: Content, Instruction/Elementary, Instruction/Middle School, Instruction/Secondary School, Instruction/Higher Education, Research

Floor 3 Springs E

Making Middle School Social Studies "Stick": Practices to Increase Student Engagement

Together we will explore strategies teachers can use not only to maximize the use of time in the middle school social studies block, but also ways that teachers can dig deeper with students through strategies that provide opportunities for collaboration, critical thinking, creativity, and communication in the middle grades.

Presenter: Albert Robertson, Lexington School District One

Focus: Instruction/Middle School

Floor 3 Springs F

The Annual Social Studies Assessment Update from the South Carolina Department of Education

Assessment and social studies in South Carolina have changed much since the program's inception in 2003 as well as during the past year. Please once again join Dr Leslie Skinner from the South Carolina Department of Education's Office of Assessment for the annual update to consider where we have been and are going in assessing the social studies discipline and our students in general.

Presenter: Leslie Skinner, SC Department of Education

Focus: Assessment/Evaluation

Floor 3 Springs G

Visual Literacy in an Inquiry Based Learning Classroom

The Breaker Boys. . .How to incorporate visual literacy into the social studies classroom through Inquiry Based Learning. Using the Breaker Boys of the Industrial Revolution, students will engage critical thinking, problem solving, collaboration, and teamwork to gain a deeper understanding of the long hours, low wages, and unsafe working conditions children laborers faced during the Industrial Revolution.

Presenters: Daniel Parent, Aiken County Public Schools
Theresa Spieker, Mossy Creek Elementary School

Focus: Instruction/Elementary, Instruction/Middle School

Floor 3 Springs H

South Carolina: Explore by Atlas, Poster, and Giant Map!

Use the Atlas of South Carolina, geography classroom posters, and the Giant Traveling Map of South Carolina to enliven your instruction.

Presenter: Larianne Collins, South Carolina Geographic Alliance

Focus: Instruction/Elementary

Floor 3 Springs J

AP U S History: A Reader's Perspective

This session will include a discussion of the rubrics for AP US History from the point of view of someone who has graded the DBQ and the long essay.

Presenter: Margaret Gillikin, Winthrop University

Focus: Assessment/Evaluation, Content, Instruction/Secondary School

Floor 2 Carolina E

ETV Does That?

Come learn about all the resources that SCETV provides for all SC Educators: LearningWhy (our new site), Knowitall.org, PBSLearningMedia.org, and PBS Kids. They also offer a variety of recertification opportunities.

Presenter: Debbie Jarrett, SCETV

Focus: Content

Floor 2 Poster Table 1

Case Studies in the Social Studies Classroom

Case studies use cross-curricular skills to engage students in critical thinking and authentic learning while enhancing content knowledge. This session focuses on design and execution of a classroom case study.

Presenters: Amanda Sevon-Lynch, Meadow Glen Middle School

Courtney Garrison, Meadow Glen Middle School

Focus: Content, Instruction/Middle School

Floor 2 Poster Table 2

History Underground: Breaking Down South Carolina's USHC Standards

A focus on the SC USHC standards that showcases pacing, classroom strategies and End of Course testing preparation by going beyond the support documents and capturing students' attention.

Presenters: Kelli Foster, History Underground LLC
Mandy Loudermilk, History Underground LLC

Focus: Assessment/Evaluation, Content, Instruction/Higher Education

Floor 2 Poster Table 3

Teaching the Arab-Israeli Conflict & Peace Process

Connect the history and background of the Arab-Israeli conflict and peace process to the present through primary source sources and teaching strategies that support close, analytic reading and evidence-based responses.

Presenter: Dori Gerber, Institute for Curriculum Services

Focus: Content, Instruction/Middle School, Instruction/Secondary School

Floor 3 Vendor Table 4

Native American Written Records

Rikki Davenport will present an engaging lesson on several aspects of Native American written records. Through winter counts, wampum belts, and petroglyphs, teachers will explore ways to engage students in learning about Native Americans history and culture through several interactive activities. A complete lesson plan for (2-3 days) will be provided. Helpful but not required: iPad or device with a QR code scanner.

Presenter: Rikki Davenport

Focus: Content

★ Lunch - 12:45-1:45 ★

Special Speaker

Hugo Schiller, Holocaust Survivor

Hugo Schiller was seven years old when Hitler's Nazis dragged his father Oskar from their home in Grünsfeld, Germany and took him to the concentration camp Dachau. Two weeks later they brought him back without explanation, and forced him to sell Rosenbusch & Company, the family store. When Hugo's school principal informed him that he could no longer go to school because he was Jewish, Hugo's parents sent him to Offenbach, Germany to live with two aunts and go to school. The morning after he arrived home for vacation break, Hitler's uniformed Nazi troops came for the family, giving them one hour to pack a suitcase and leave. Hugo and his family were deported to Gurs, a refugee camp in the South of France where they were held behind barbed wire in intolerable living conditions and with scanty food. At the muddy Gurs camp near the Pyrenees Mountains, Hugo sang for bread for his Mother Selma and Aunt Hilda who were starving. One day cheerful Alice Resch drove into Camp de Gurs in a truck with a canvas flapping on the back. Working with the Quaker Refugee Relief agency, she had gained permission from the Vichy French Government to help feed the children. Soon after, she gained permission to take Hugo and the other children from Gurs to the children's home in Aspet. In Hugo's true story there is unspeakable loss but also great triumph on many levels. Hugo Schiller, child-hero, bravely survived the Holocaust by helping others. Today, he speaks about his experiences and about how to help make certain a Holocaust never happens again. **Remember Singing** is a book written about Schiller and his experiences during the Holocaust.

Session 4

1:55 - 2:45

Floor 3 Springs A

ESOL - Who, What, Where, When and HOW?

Let's talk about our ever growing population of ESOL/ELL students. Who are they and how can we meet the needs of these students to help them to be successful?

Presenter: Nancy Machamer, Palmetto Middle School

Focus: Multipurpose/General

Floor 3 Springs B

Authentic & Engaging Social Studies in the Elementary Grades

Together we will explore strategies teachers can use not only to maximize the use of limited time in the elementary social studies block, but also ways that teachers can dig deeper with students through strategies that provide opportunities for collaboration, critical thinking, creativity, and communication.

Presenter: Albert Robertson, Lexington School District One

Focus: Administration, Assessment/Evaluation, Content, Instruction//Elementary

Floor 3 Springs C

Engaging Review Strategies

Are you looking to integrate different review strategies in your classroom? We will highlight some that can be used with or without technology to review throughout the year.

Presenter: Elizabeth King, South Carolina Department of Education

Stephen Corsini, South Carolina Department of Education

Focus: Assessment/Evaluation, Content, Instruction/Elementary, Instruction/Middle School, Instruction/Secondary School, Instruction/Higher Education

Floor 3 Springs D

Reading Like Historians: Experience a Two-Day Inquiry Using Three Primary Documents

Explore a two-day, arts-infused, inquiry-based history lesson incorporating the language and strategies historical readers employ to synthesize learning and go public with new understandings. Very applicable to all grades and social studies standards.

Presenter: Nicole Bishop, Irmo Elementary School

Focus: Content, Instruction/Elementary

Floor 3 Springs E

Days of Future Past: The Social Studies Classroom in the 21st Century

This session looks at a blended classroom model focused on historical concepts and historical thinking skills taught through content modules, projects and simulations. Participants will receive rubrics and sample activities.

Presenters: Kason Dalton, Dent Middle School

Marc Turner, Dent Middle School

Focus: Assessment/Evaluation, Content, Instruction: Middle School, Instruction: Secondary School

Floor 3 Springs F

Exploring the LOC Primary Sources

Discover and explore the Library of Congress plethora of primary sources that can be used in grades K-12. During this session you will discover how to begin using primary sources in your classroom to introduce topics, guide them to higher-order thinking and better critical thinking and analysis skills.

Presenters: Anne C. Lemieux, Lugoff-Elgin High School

Cathy Epps, Lugoff-Elgin Middle School

Focus: Instruction/Elementary, Instruction/Middle School, Instruction/Secondary School

Floor 3 Springs G

Using Historical Fiction to Teach about the Holocaust & Genocide

What do you use? Diary of Ann Frank? Number the Stars? This session will suggest some new books for you to use in your Holocaust & Genocide units regardless of your grade level. Yes, high school, there are great picture books out there for you to use in your units. You'll receive suggestions, bibliographical lists, lessons, and much more. Come and get some great ideas for your class!

Presenter: James Bryan, SC Teacher Advisor Committee for the SC Council on the Holocaust

Focus: Content, Literacy, Instruction/Elementary, Instruction/Middle School, Instruction/Secondary

Floor 3 Springs H

Mystery Skype – Learning without Borders

Explore the power of Mystery Skype by learning how to collaborate with students across the globe, connect with guest speakers, and take virtual field trips with Skype in the Classroom.

Presenter: Larianne Collins, South Carolina Geographic Alliance

Focus: Instruction/Middle School

Floor 3 Springs J

Explaining the New AP History Writing Rubrics

In June, the College Board announced new scoring guidelines for DBQ and LEQ essays. We will explain the changes and how they will impact teaching writing in AP History courses.

Presenter: Tom Richey, Seneca High School

Matt Rose, Spring Hill High School

Focus: Instruction/Secondary School

Floor 2 Carolina E

Webtools for Teachers

Let us share some of our favorite FREE webtools. Join us and we will share some of our favorites.

Presenter: Debbie Jarrett, SCETV

Focus: Instruction/Elementary, Instruction/Middle School, Instruction/Secondary School, Instruction/Higher Education, Multipurpose/General

Floor 2 Poster Table 1

Online vs. Face-to-Face Discussions

This session will present preliminary research exploring online vs. face-to-face discussion strategies in terms of how often and how well students participate in each discussion format.

Presenters: Brian Genneralli and Savannah Scarborough, Coastal Carolina University

Kristal Curry, Coastal Carolina University

Suzanne Horn, Coastal Carolina University

Focus: Instruction/Secondary School, Research

Floor 2 Poster Table 2

What's YOUR Story?

Come to this session to be a part of history and record first person accounts of major historical events that occurred in your lifetime. Come learn how to apply this to your classroom!

Presenter: Tracy Todd, Easley High School

Focus: Instruction/Secondary School

Floor 2 Poster Table 3

I Found It!: Using Scavenger Hunts to Explore Local History

This session explores using scavenger hunts to discover local history. Participants engage with a scavenger hunt from nearby Conway, SC. We also discuss designing and implementing your own scavenger hunts. {2-hour session}

Presenter: Heather N. Hagan, Coastal Carolina University

Focus: Instruction/Elementary, Instruction/Middle School, Instruction/Secondary School, Instruction/Higher Education, Multipurpose/General

Floor 2 Poster Table 4

2018 Summer Institute for School Teachers: America's Reconstruction - The Untold Story

I invite you to learn about this exciting opportunity to participate in the 2018 class of "America's Reconstruction: The Untold Story," for K-12 teachers. Supported by the National Endowment for the Humanities (NEH), hosted by the University of South Carolina Beaufort in partnership with the City of Beaufort, the University of South Carolina College of Education, the Beaufort Museum, and the historic Penn Center, and held at the Historic Beaufort campus of the University of South Carolina Beaufort (USCB) in the summer of 2018. Learn about the application process, the institute, and expectations for this 3-week course that takes in Beaufort, SC. Those chosen to participate will receive a stipend by the NEH to immerse yourself in this vital, yet often misunderstood, Era of American History.

Presenter: Brian Day, Sandy Run K-8 School

Focus: Content, Multipurpose/General

Session 5

2:55 - 3:45

Floor 3 Springs A

Active Seating in the Social Studies Classroom

Want to increase student engagement? We will provide funding opportunities and strategies for implementing active seating in the classroom. Session provides successful assessment and behavioral results from implementation.

Presenters: Courtney Garrison, Meadow Glen Middle School
Amanda Sevon-Lynch, Meadow Glen Middle School

Focus: Instruction/Middle School, Multipurpose/General, Research

Floor 3 Springs B

Writing Journey for a Personal, Different Perspective on Hiroshima

*Japanese American author, discusses the message and story behind *The Last Cherry Blossom*; based on events in her twelve-year-old mother's life in Hiroshima during World War II, and surviving the atomic bomb.*

Presenter: Kathleen Burkinshaw, Author

Focus: Instruction/Middle School, Instruction/Secondary School

Floor 3 Springs C

Developing Compelling Questions

Writing compelling questions is challenging. This session will provide opportunities to analyze examples of compelling questions with time to develop your own.

Presenters: Elizabeth King, South Carolina Department of Education
Rebecca Mueller, Ph.D., University of South Carolina Upstate

Focus: Instruction/Elementary, Instruction/Middle School, Instruction/Secondary School

Floor 3 Springs D

Beyond February: Resources for Seamlessly Integrating African American History Content

In this session you will learn of a hosts of online teaching resources, webinars and events that are classroom ready for the facilitation of teaching African American history. You will also learn teaching tips to help weave African American history throughout your curriculum. All resources are free to teachers and students.

Presenter: Connie Blyther, South Carolina Conference for African American Studies

Focus: Content, Instruction/Elementary, Instruction/Middle School, Instruction/Secondary School, Multipurpose/General

Floor 3 Springs E

What! Social Studies Can Support ELA with the TDA Process?

Social studies teachers have integrated documents as a means for critical thinking and inquiry-based learning for decades. Learn how pre-planning of integration between social studies and ELA has eased the TDA fear in our school district.

Presenter: Heather Brabham, Beaufort County School District

Focus: Content, Instruction/Elementary, Instruction/Middle School

Floor 3 Springs F

But There's Gotta Be Power-Ups!: Game Design in the Classroom

If school is a game then there has to be powerups! Learn to use game design principles to create leveling, belt ranking, and power up systems for your classroom.

Presenter: Adam Powley, HCS Early College High School

Focus: Assessment/Evaluation, Instruction/Elementary, Instruction/Middle School, Instruction/Secondary School

Floor 3 Springs G

SoundTracks: Songs that Defined History

If you missed this CNN series, then don't miss media educator Frank Baker's session designed to showcase the music, and the songs, and how to incorporate them into instruction.

Presenter: Frank W Baker, Media Literacy Clearinghouse Inc

Focus: Content, Instruction/Middle School, Instruction/Secondary School, Multipurpose/General

Floor 3 Springs H

3-D Mapping to Develop Geographic Understanding with Students with I/DD

This session introduces three-dimensional mapping as a tool for developing geographic understanding. It then explores using the concept to build navigational skills amongst students with I/DD in a post-secondary setting.

Presenter: Heather N. Hagan, Coastal Carolina University

Sharon Richter, Coastal Carolina University

Focus: Content, Instruction/Higher Education

Floor 3 Springs J

Incorporating RTI in the HS Social Studies Classroom

Northwestern High School has incorporated RTI time, or PEAK time as we call it, into our daily schedule. This session will focus on the benefits of RTI time on student academic performance and will introduce some strategies that have proven effective in raising student achievement.

Presenter: Jacqueline Persinski, Northwestern High School

Focus: Administration, Assessment/Evaluation, Content, Instruction: Secondary School, Research

Floor 2 Carolina E

McGraw-Hill Networks Online Platform with LearnSmart

McGraw-Hill LearnSmart is an adaptive learning system designed to help students learn faster, study more efficiently, and retain more knowledge for greater success. LearnSmart provides each student with a unique, individualized learning path to help them increase knowledge and competencies while helping to make class time more interactive and productive!

Presenter: Jane Dennerlein, McGraw-Hill Education

Focus: Administration, Assessment/Evaluation, Content, Instruction/Middle School, Instruction/Secondary School, Instruction/Higher Education

Floor 2 Poster Table 1

Singing Your Way Through American History

This presentation focuses on both historical period songs and later songs written about historical periods and figures that serve as excellent teaching tools for American History students.

Presenters: Rusty Godfrey, SC Governor's School for the Arts and Humanities

Jamelle Gestwicki, SC Governor's School for the Arts and Humanities

Focus: Instruction/Middle School, Instruction/Secondary School

Floor 2 Poster Table 2

What's YOUR Story?

Come to this session to be a part of history and record first person accounts of major historical events that occurred in your lifetime. Come learn how to apply this to your classroom!

Presenter: Tracy Todd, Easley High School

Focus: Instruction/Secondary

Session 6

3:55-4:45

Floor 3 Springs A

Making It Relevant: Teaching Social Studies Through Simulations

Often times, social studies concepts are abstract for students because they were not able to experience the events themselves. Teaching events through classroom simulations provides students with real, tangible connections to content.

Presenter: Briana Vereen, Arden Elementary

Focus: Content, Instruction: Elementary

Floor 3 Springs B

Bringing World War II Hiroshima & Historical Fiction to the Modern Classroom

*Kathleen Burkinshaw, MG author, will discuss how historical fiction can be used to enhance curriculum as well as how classes have used her book, *The Last Cherry Blossom*; which was inspired by events in her mother's life in Hiroshima during WWII and surviving the atomic bombing on August 6th.*

Presenter: Kathleen Burkinshaw, Author, SCBWI Carolinas RegionP

Focus: Instruction/Elementary, Instruction/Middle School, Instruction/Secondary School

Floor 3 Springs C

Using DBQs

Document Based Questions (DBQs) can be integrated in all levels of learning - not just AP. We will explore DBQs created by South Carolina teachers for students in grades 3, 4, 5, 8 and 11.

Presenters: Elizabeth King, South Carolina Department of Education

Matt Rose, Spring Hill High School

Focus: Content, Instruction/Elementary, Instruction/Middle School, Instruction/Secondary School

Floor 3 Springs D

Bringing PBL's to Your Social Studies Classroom

Heard about PBL's but you're not really sure what they are? Looking for ways to amp your projects into Project Based Learning? Come hear about practical steps for implementing PBL's in your classroom or school.

Presenter: Karen Teague, Greenwood District 50

Focus: Content, Instruction: Middle School, Instruction: Secondary School

Floor 3 Springs E

Reaching ELLs - Building Context, Confidence, & Vocabulary in World History

Presentation will focus on strategies for ELLs including technology-enhanced, interactive lessons. The session will share specific research-based strategies that led to success in my own classroom through the lens of a 7th grade case study named Sebastian.

Presenter: Katherine A. King, Lakeview Middle School, Greenville County School

Focus: Assessment/Evaluation, Content, Instruction/Middle School

Floor 3 Springs F

Engagement through Collaboration: Planning for Success with Verso App

The session will focus on combining cooperative learning and the Verso App to allow students individually and in combined groups to answer an opened ended question posed to them by their teacher. This allows for engagement through collaboration, while providing students with multiple opportunities to explore the thinking of others.

Presenters: Stephanie Shirley, St. James Middle School
Samantha House, St. James Middle School

Focus: Instruction/Middle School

Floor 3 Springs G

Ken Burns' Vietnam: Examining the Education Aspects

Join media educator Frank Baker for ideas on how to teach with Ken Burns' series "The Vietnam War." Excerpts from the PBS series will be shown and educational content shared.

Presenter: Frank W Baker, Media Literacy Clearinghouse, Inc.

Focus: Instruction/Middle School, Instruction/Secondary School, Multipurpose/General

Floor 3 Springs H

SC Social Studies Professors Meeting

All social studies professors will meet to discuss issues and focus for the coming year.

Presenter: George Lipscomb, Furman University

Focus: Multipurpose/General

Floor 3 Springs J

U S History and English III Reading and Writing Collaboration

Together, U S History and English III teachers share common students and content, so why not work together to improve student learning and achievement? This session will share reading, writing, and research lessons we have created and are implementing in our English III and US History classrooms.

Presenters: Jacqueline Persinski, EdD, Northwestern High School
Melissa Lehman, Northwestern High School
Candice Phillips, Northwestern High School

Focus: Administration, Assessment/Evaluation, Content, Instruction/Secondary School

Floor 2 Carolina E

Active Learning in the World History Classroom

This lively session will demonstrate how active classroom strategies can create interactive opportunities for students to discuss and share ideas about world history content. Participants will acquire best practices to integrate quick and easy energizer activities into their lessons. These strategies will deepen the level of classroom discussion by focusing on important processing skills and encouraging students to justify their thinking.

Presenter: Lisa Jurovaty

Focus: Instruction/Secondary School

Floor 2 Poster Table 1

Inquiry Based Introductions to Geographic Thinking

This session will demonstrate inquiry based lessons for grade 9 – 12 teachers of geography. We demonstrate inquiry based, "no technology needed" lessons to introduce geospatial thinking and problem solving.

Presenter: Evan Sellers, Academy for the Arts, Science and Technology

Focus: Instruction/Secondary School

Floor 2 Poster Table 2

Gallery Walk: The Most Versatile Lesson Plan Out There!

The Gallery Walk is a more mature form of stations. It allows students to be up and moving and working at their own pace. There are so many ways this activity can be used. Come in and learn how the activity is set up and how it can be modified for any of your needs!

Presenter: Kristen Smith, Mauldin Middle School

Focus: Assessment/Evaluation, Content, Instruction/Middle School, Instruction/Secondary School, Research

SCCSS Agenda

Saturday—September 30, 2017

General Session

8:00 - 9:00

Continental Breakfast

9:00 – 10:00

Presentation of SCCSS Awards

Guest Speaker

You All Get an F

Jed Dearybury

Director of Professional Development &

Communications

Palmetto State Teachers Association

Jed Dearybury is an award winning early childhood/elementary teacher from Spartanburg, SC. Over the last 16 years, while teaching grades 1-3, Dearybury has been named County Reading Teacher of the Year, Presidential Award for Excellence in Math and Science Teaching Award Winner, allowing him the privilege of being recognized by President Obama at the White House, School level Teacher of the Year twice, District Teacher of the Year, Top 5 finalist for SC Teacher of the Year, Donors Choose Innovator, and GQ Male Leader of the Year for 2013. He is a frequent presenter at state and national conferences, where he models best practices with technology, music, drama, visual, and performing arts for the regular classroom educator. Need supplies for your classroom? Jed is a donorschoose.org guru. He has had over 100 projects funded for his students, totaling over \$25,000 in materials! Need a jingle or educational song? Jed is your composer. He has written numerous parodies and original songs to help teach content to his students. Want to build a classroom website or blog, Jed can help you! Check out www.mrdearybury.com. He also serves on the education council for the Lily, Sarah, Grace Fund. LSG is a nonprofit organization that helps fund the arts in underfunded public schools across the nation and provides inquiry based learning professional development to educators seeking to break out of the traditional education box. Currently, he serves as the Director of Professional Development & Communications for the Palmetto State Teachers Association. He works with schools and teachers across SC to help their classrooms be innovative hubs for student learning. When he isn't teaching, he is running. 7 full marathons, 10 half marathons, countless 10ks and 5ks... and counting!

Saturday Concurrent Session 1

10:00 – 10 50

Springs F

Empowering Society's Marginalized Groups: The Economics of Inclusion

With populist movements gaining traction in many countries and a worldwide refugee crisis, it is an important time to highlight key issues that hinder economic freedom and opportunity. Using a "BreakOut Box", this session will delve into the importance of inclusion to economic well-being of all members of society by providing key elements that teachers can use to teach about issues related to race, gender, and immigration.

Presenter: Amanda Stiglbauer, SC Economics/Richland Northeast High School

Focus: Content, Instruction: Secondary School, Research

Springs G

The Press Vs The Presidency: A Media Literacy Lesson

The president declared "the press is the enemy of the people." Join media educator Frank Baker for ideas on how to talk about the role of the media during the current presidency.

Presenter: Frank W Baker, Media Literacy Clearinghouse Inc.
Focus: Content

Springs H

Continuity & Changes – 2020 Social Studies Elementary Standards

This session will highlight the timeline of the new standards thus far, the steps taken to craft them, and the next steps for approval. Be among the first to gain insight into the incredible future of social studies in South Carolina!

Presenter: Elizabeth King, South Carolina Department of Education
Stephen Corsini, South Carolina Department of Education
Focus: Standards/Elementary

Saturday Concurrent Session 2
11:00 – 11:50

Springs F

The Economic Impact of Disasters

What do the Black Plague, the Spanish Influenza, the Indonesian Tsunami (2004) and Hurricane Matthew have in common? Each of these disasters has been subject to the centuries old question, "Are disasters good for the economy?" This presentation will use the concepts of scarcity, productivity, a simple graphic model, and historical analysis to explain how disasters change our ability to satisfy wants and needs and challenge participants to formulate evidence based conclusions about the economic impact of disasters.

Presenter: Amanda Stiglbauer, SC Economics/Richland Northeast High School
Focus: Content, Instruction/Middle School, Instruction/Secondary School

Springs G

Continuity and Changes – 2020 Social Studies Middle Standards

This session will highlight the timeline of the new standards thus far, the steps taken to craft them, and the next steps for approval. Be among the first to gain insight into the incredible future of social studies in South Carolina!

Presenter: Elizabeth King, South Carolina Department of Education
Stephen Corsini, South Carolina Department of Education

Springs H

Continuity and Changes – 2020 Social Studies High School Standards

This session will highlight the timeline of the new standards thus far, the steps taken to craft them, and the next steps for approval. Be among the first to gain insight into the incredible future of social studies in South Carolina!

Presenter: Elizabeth King, South Carolina Department of Education
Stephen Corsini, South Carolina Department of Education
Focus: Standards/Middle Level, Standards/High School